

Junkers Ju-87 D-3

"STUKA"



By Chuck

TABLE OF CONTENTS

- PART I: THE AIRCRAFT
- PART II: THE CONTROLS
- PART III: TAKEOFF
- PART IV: LANDING
- PART V: ENGINE MANAGEMENT
- PART VI: AIRCRAFT PERFORMANCE

	(Unit)	LaGG-3	Yak-1	La-5	Il-2	Pe-2	Bf.109F4	Bf.109G2	Fw190A3	Ju-87	He-111
--	--------	--------	-------	------	------	------	----------	----------	---------	-------	--------

TEMPERATURES

Water Rad Min	Deg C	80	80	-	80	40	40	40	-	60	40
Max		100	100		110	100	100	100		100-110	95
Oil Rad (OUTBOUND) Min	Deg C	40	40	55	70	-	40	40	40	30	35
Max		100	100	75	115		80	80	110	105	95
Oil Rad (INBOUND) Min	Deg C	-	-	-	40	-	-	-	-	-	-
Max					80						
Cylinder Head Temp Min	Deg C	-	-	120	-	-	-	-	-	-	-
Max				200							

ENGINE SETTINGS

Takeoff RPM	RPM	2700	2700	2400	2200	2700	2600	2500	2500	2500	2400
Takeoff Manifold Pressure	RU: mm Hg GER: ATA	1050	1050	1150	1150	1050	1.3	1.3	1.3	1.3	1.35
Climb RPM	RPM	2600	2650	2300	2050	2600	2600 30 min	2500	2400	2450 30 min	2300 30 min
Climb Manifold Pressure	RU: mm Hg GER: ATA	1020	1050	1150	1050	1050	1.3 30 min	1.3	1.3	1.25 30 min	1.15 30 min
Normal Operation/Cruise RPM	RPM	1700	1850	2300	1850	2200	2200	1900	2200	2100	2200
Normal Operation/Cruise Manifold Pressure	RU: mm Hg GER: ATA	1020	850	900	850	1020	1.0	1.0	1.1	1.2	1.10
Combat RPM	RPM	2650	2650	2400	2050	2600	2600	2500	2400	2250	2300
Combat Manifold Pressure	RU: mm Hg GER: ATA	1050	1050	1150	1050	1050	1.3	1.3	1.32	1.2	1.15
Emergency Power/ Boost RPM @ km	RPM	2700	2700	2400 10 min max	2200	2700	2700 1 min max	2500	2600 7-8 min max	2600 1 min max	2400 1 min max
Emergency Power / Boost Manifold Pressure @ 1 km	RU: mm Hg GER: ATA	1050	1050	1150 10 min max	1150	1050	1.42 1 min max	1.3	1.42 7-8 min Max	1.4 1 min max	1.35 1 min max
Supercharger Stage 1 Operation Altitude	m	0 2000	0 2500	0 2000	-	0 2000	-	-	-	Auto/man modes	Auto/man modes
Supercharger Stage 2 Operation Altitude	m	2000+	2500+	2000+	-	2000+	-	-	-	Auto/man modes	Auto/man modes
*Landing Approach RPM	RPM	2600	2200	2400	1800	2700	1500	1500	-	2000	2300
*Landing Approach Manifold Pressure	RU: mm Hg GER: ATA	As required	600	As required	600	As required	0.6	0.6	-	0.6	As required
Notes				Open Oil Radiator at all times	Close Oil radiator in combat	Flaps 30 on Takeoff & 15 on Landing			Lock tailwheel on takeoff	No Abrupt Throttling	Eng. very sensitive to ata/rpm

AIRSPEEDS

Takeoff – Rotation	km/h	190	200	180	190	250	180	180	200	170	150
Optimal Climb Speed	km/h	270	260	250	250	240	280	280	270	230	N/A
Landing – Approach	km/h	200	180	200	200	200	180	180	190	190	200
Landing – Touchdown	km/h	170	150	170	150	160	160	160	150	150	140-150

History

IL★2 Chuck O.

The Junkers Ju-87 or Stuka (from Sturzkampfflugzeug, “dive bomber”), was a two-man German dive bomber and ground-attack aircraft. Designed by Hermann Pohlmann, the Stuka first flew in 1935 and made its combat debut in 1936 as part of the Luftwaffe's Condor Legion during the Spanish Civil War.

The aircraft was easily recognisable by its inverted gull wings and fixed spatted undercarriage, upon the leading edges of its faired main gear legs were mounted the Jericho-Trompete ("Jericho Trumpet") wailing sirens, becoming the propaganda symbol of German air power and the blitzkrieg victories of 1939–1942. The Stuka's design included several innovative features, including automatic pull-up dive brakes under both wings to ensure that the aircraft recovered from its attack dive even if the pilot blacked out from the high acceleration.

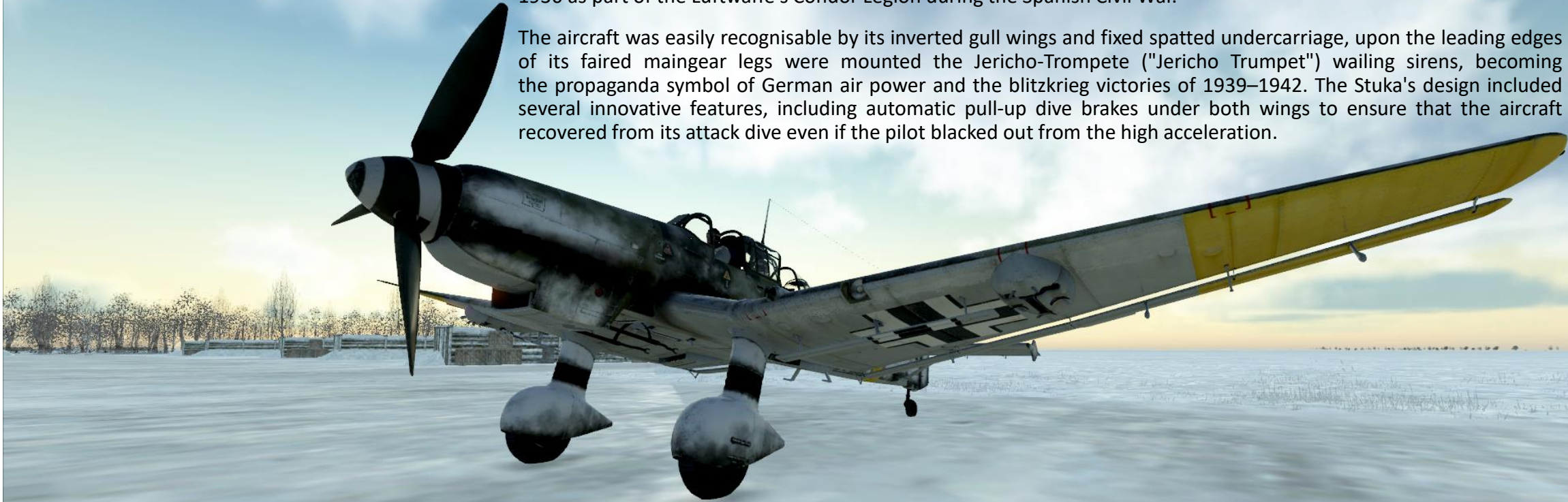

Although sturdy, accurate, and very effective against ground targets, the Ju 87, like many other dive bombers of the war, was vulnerable to modern fighter aircraft. Its flaws became apparent during the Battle of Britain; poor manoeuvrability and a lack of both speed and defensive armament meant that the Stuka required heavy fighter escort to operate effectively.

Despite the Stuka's vulnerability to enemy fighters having been exposed during the Battle of Britain, the Luftwaffe had no choice but to continue its development, as there was no replacement aircraft in sight. The result was the D-series. The Ju 87 D-series featured two coolant radiators underneath the inboard sections of the wings, while the oil cooler was relocated to the position formerly occupied by the coolant radiator. The D-series also introduced an aerodynamically refined cockpit with better visibility and space. Towards the end of the war, as the Allies gained air supremacy, the Stuka was being replaced by ground-attack versions of the Fw 190. By early 1944, the number of Ju 87 units and operational aircraft terminally declined.

The Cockpit



PART I: THE AIRCRAFT

Left Side

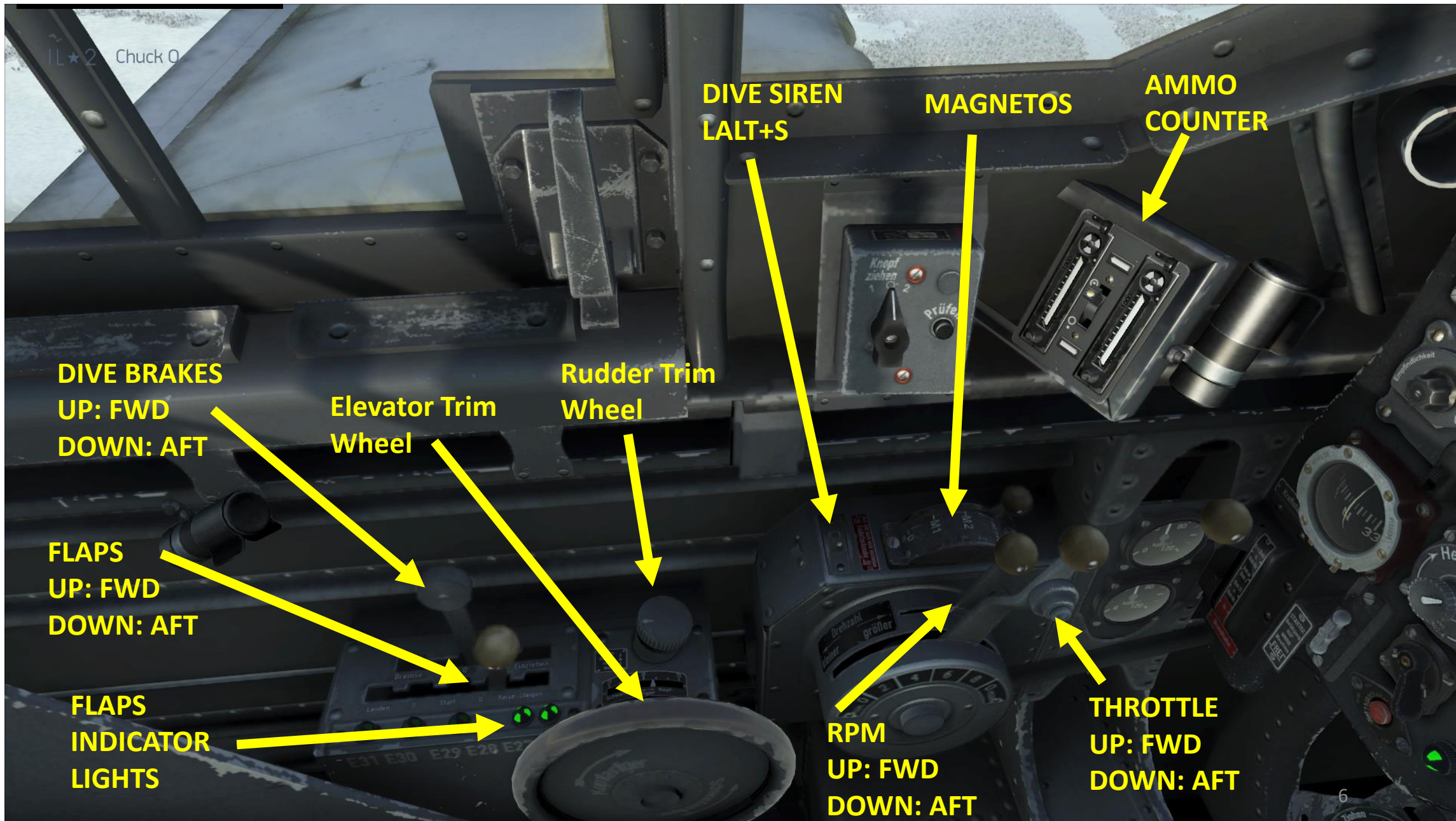

PART I: THE AIRCRAFT

Right Side

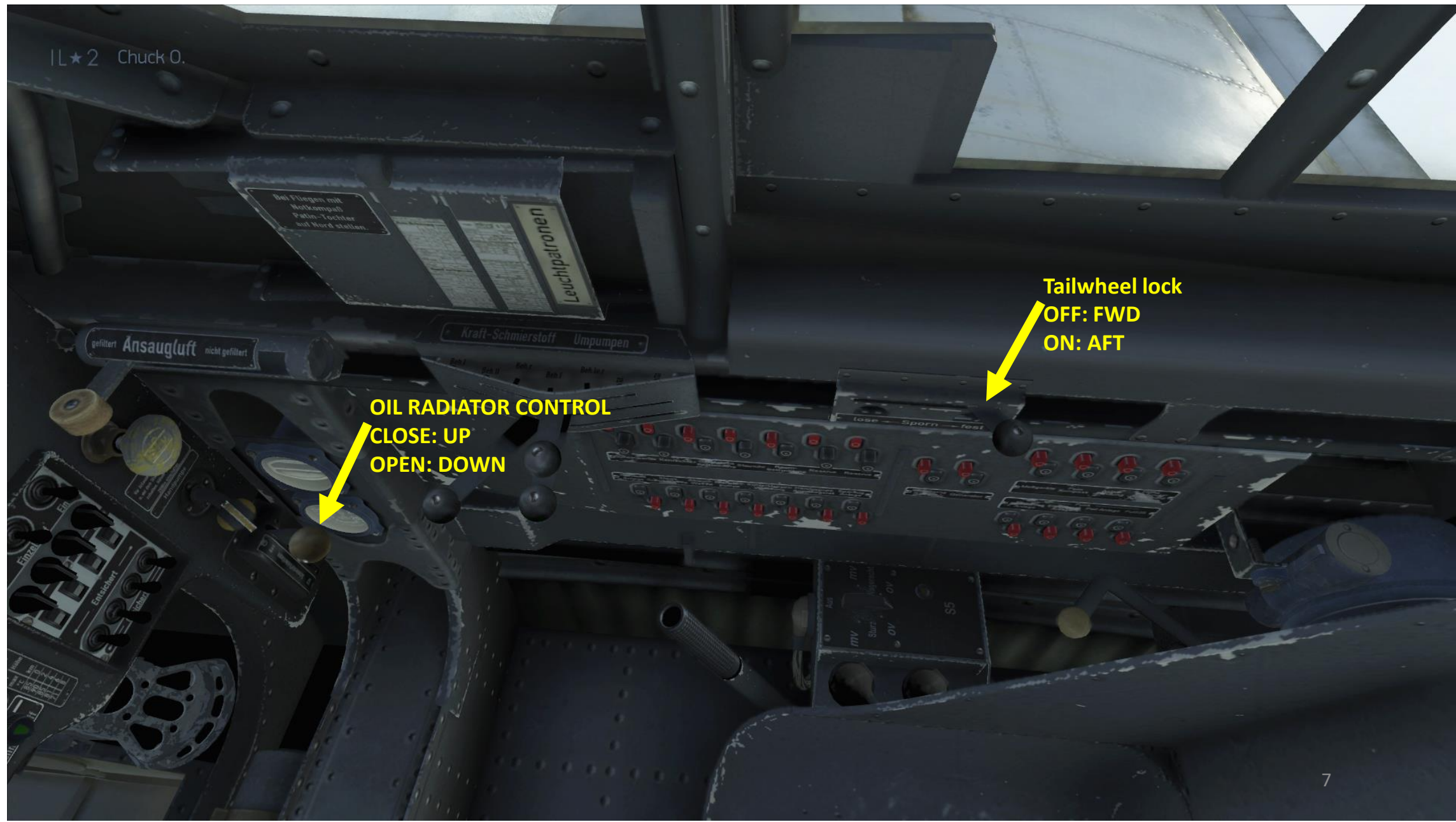

PART I: THE AIRCRAFT

Front

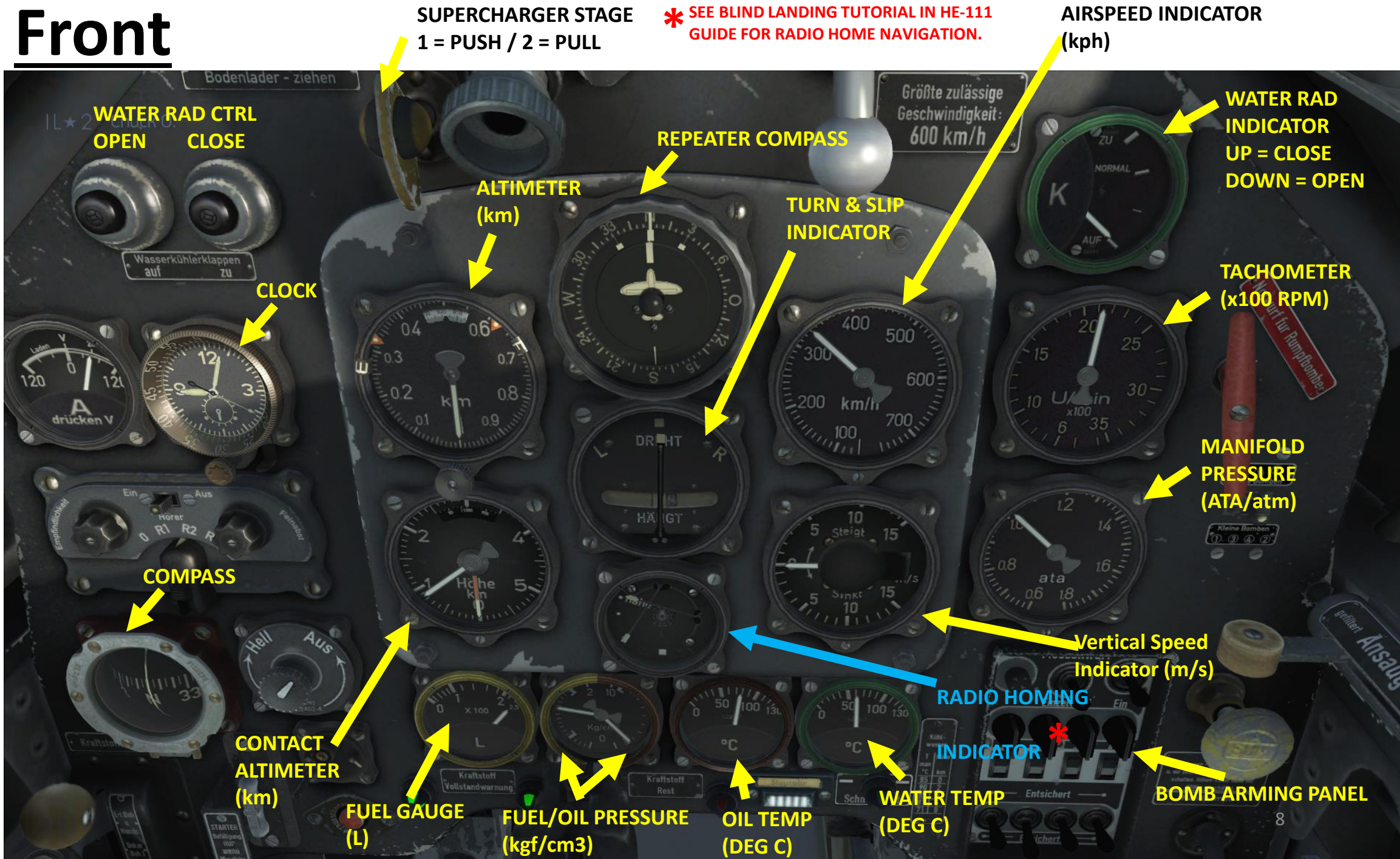

Turret Operation

- For the turret gunner, make sure that you give him the command to fire at will (Ralt + 1)
- Also, give him the command to fire at long range (Ralt + 9)
- Flying in close formation with other bombers maximizes your firepower.

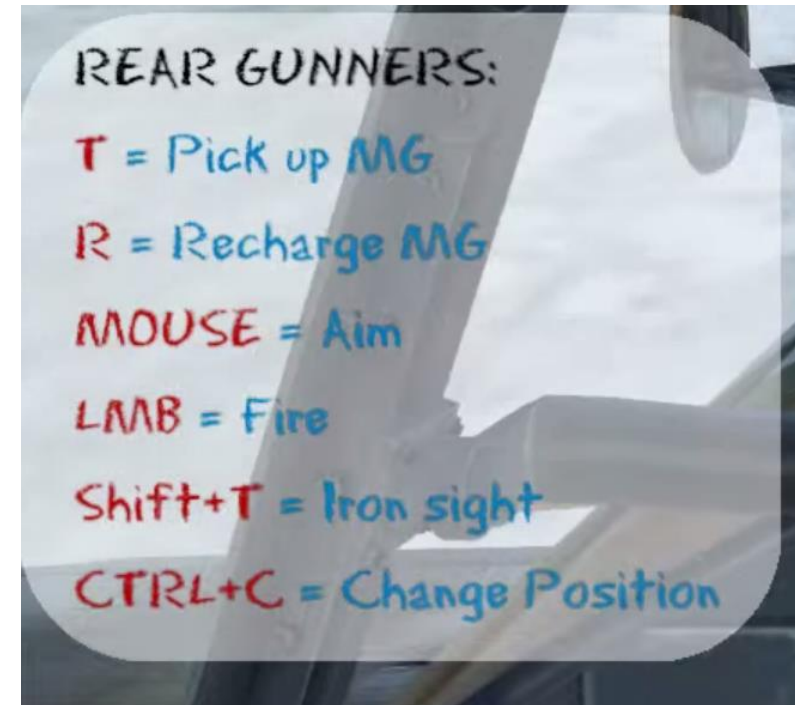

Important key bindings

- The Ju-87 has manual water and oil radiator controls unlike the 109 and 190. Also, its RPM is controlled manually. Keep that in mind when assigning your keys.
- Unlike in Russian aircraft, you do not control your mixture setting in the Ju-87.
- When going on dive bomb run, make sure that you deploy your dive brakes beforehand or your wings will simply fly away from you (literally).

PART II: THE CONTROLS

Important key bindings

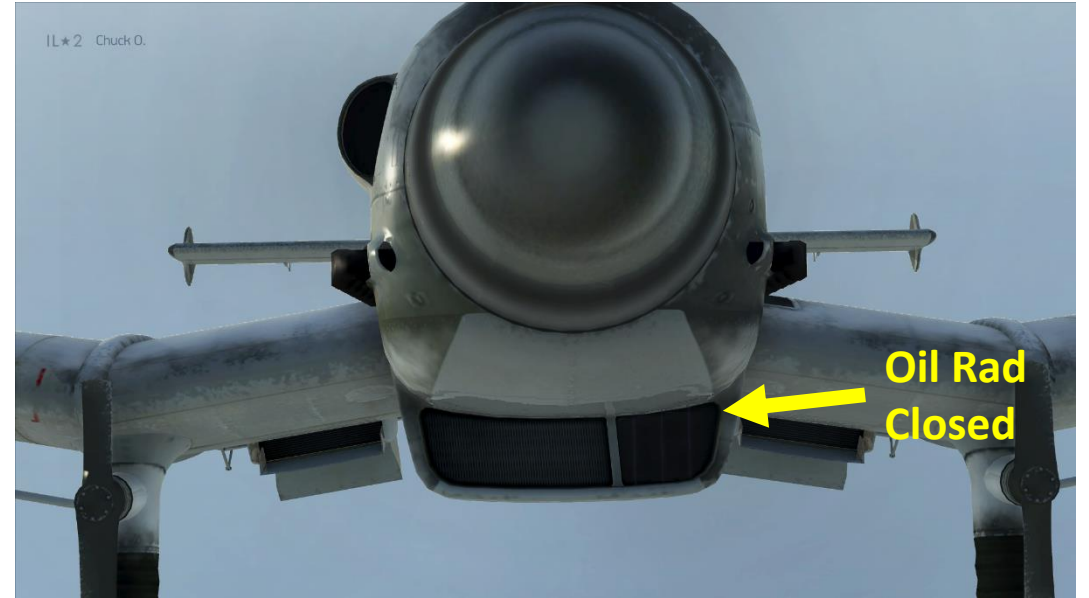

Important key bindings

OPEN/CLOSE FLOOR WINDOW FOR DIVE BOMBING USING THE "OPEN BOMB BAY DOOR" KEY ("N" BY DEFAULT)

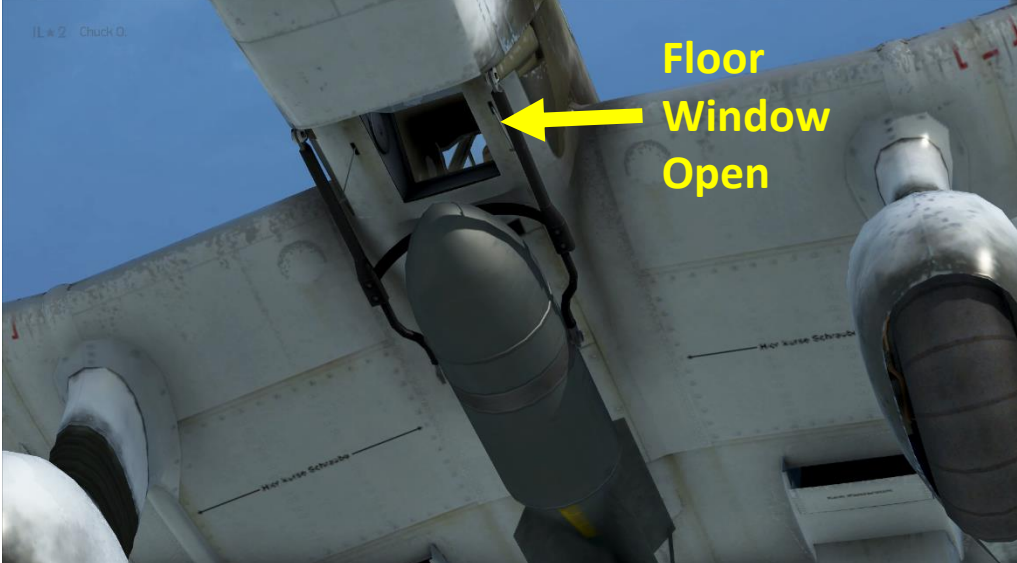

Some not so important key bindings

- Use of Jericho trumpet is recommended if you want to act all badass and stuff. Default key is LAlt+S.

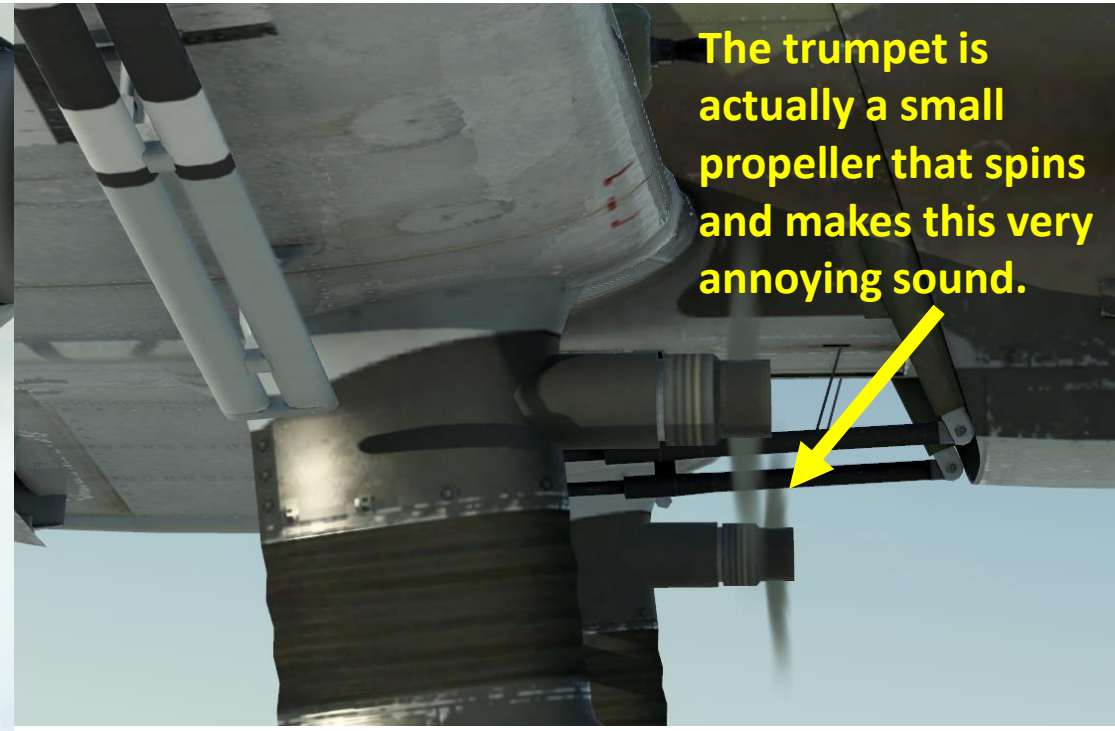
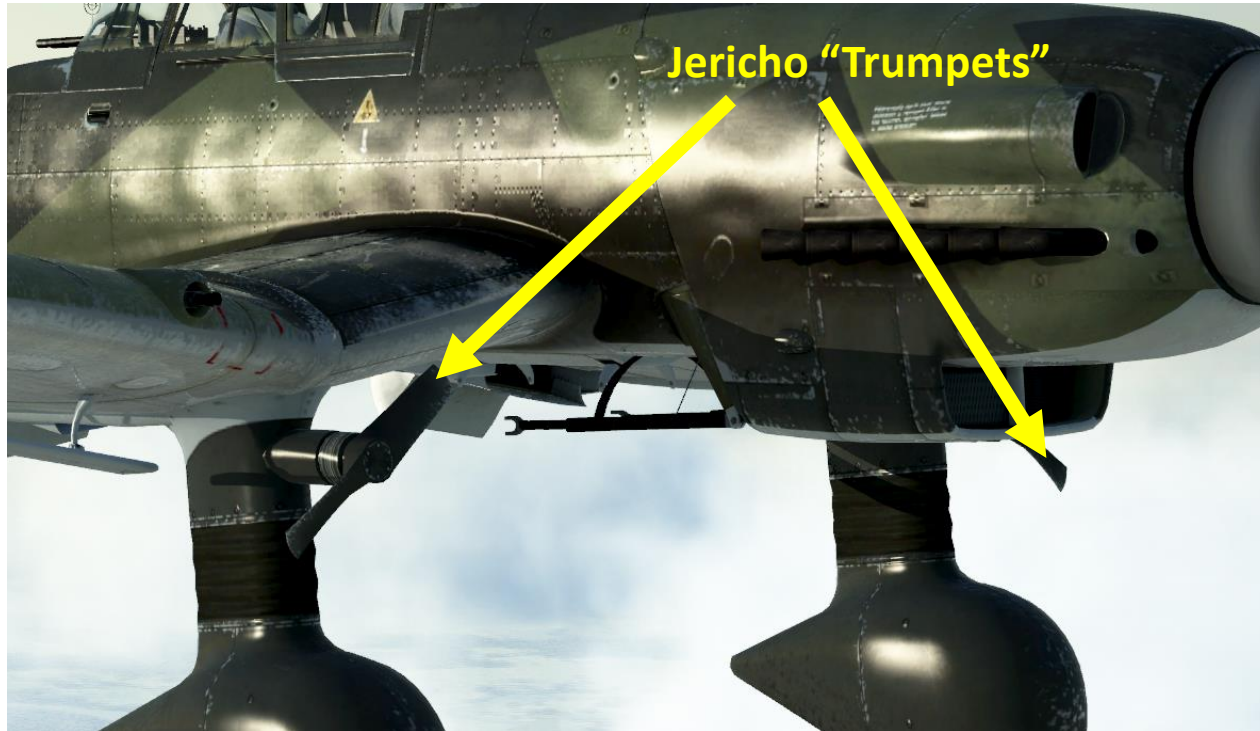

Important key bindings

- The Ju-87, unlike most Russian planes, has a “toe brake” or “heel brake” system, which is linked to each individual wheel of your landing gear.
- In order to brake, you need to hold either your left or right wheel toe brake key to steer your aircraft.
- The main landing wheel brake system employs hydraulically actuated disc-type brakes. Each brake is operated by individual master brake cylinders located directly forward of the instrument panel. The brakes are selectively controlled by means of toe pedals incorporated into the rudder pedal assembly.

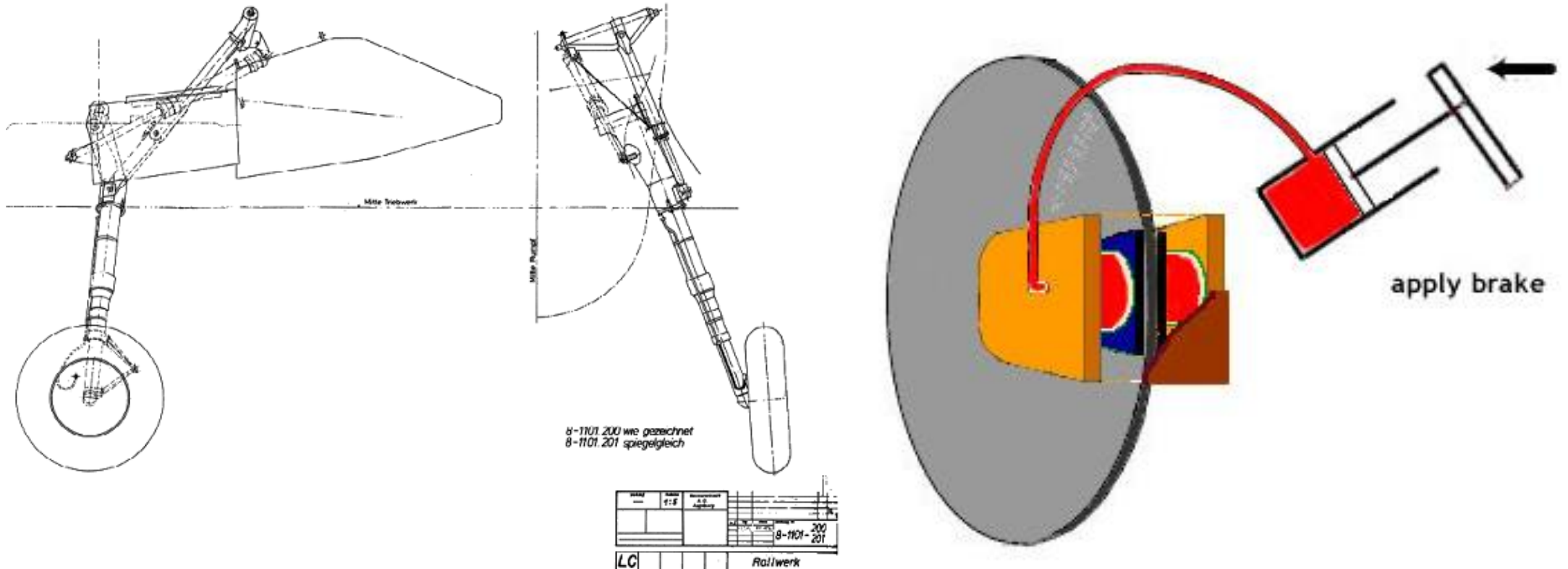

PART III: TAKEOFF

- Taking off in the Ju-87 is straightforward if you follow these steps for a cold engine start.
 - 1) Crack your throttle about 15 %
 - 2) Set your RPM to min (fully back)
 - 3) Ignite (“E” key by default)!
 - 4) Close your water and oil radiators.
 - 5) Wait for your oil temperature to reach 30 degrees C and your coolant (water) temperature to reach 80 deg C.
 - 6) Taxi to the runway (unlock tailwheel, LShift+G by default)

PART III: TAKEOFF

- 7) Set your flaps to takeoff position (1 notch) and open your coolant (water) and oil radiator flaps.
- 8) Lock your tailwheel once lined up on the runway (LShift+G by default)
- 9) Throttle up to 2500 RPM @ 1.3 ATA. Use full throttle and max RPM in case of scramble takeoff. Correct heading with small rudder input.

CAUTION: DO NOT EXCEED 1 MINUTE AT FULL POWER (2600 RPM/1.40 ATA)
CAUTION: INCREASE THROTTLE VERY GRADUALLY: ENGINE IS SENSITIVE TO ABRUPT CHANGES IN MANIFOLD PRESSURE AND RPM.

- 10) As soon as you reach 120 kph, center the stick and level out to pick some speed.
- 11) When you reach 170 kph, rotate gently.
- 12) Once you are up in the air, retract flaps, do not try to pull your landing gear up (because it's fixed... d'uh) and start climbing. Adjust manifold pressure accordingly (see engine management in part V).

PART IV: LANDING

- 1) Do not try to deploy landing gear: it's fixed! 😊
- 2) Deploy flaps to stage 1 (1 notch) when going slower than 250 kph.
- 3) Set your RPM to 2000 and adjust throttle input as required to maintain approach speed at 190 kph. Recommended engine setting is 2000 RPM @ 0.6 ATA.
- 4) Trim nose down as flaps generate extra lift.
- 5) Cut throttle when reaching runway and start a gentle, but firm flare.
- 6) Touchdown at 150 kph.
- 7) Once on the ground, pull back on the stick to lock your tailwheel and tap your brakes.



Powerplant

The Ju-87D is powered by the Junkers **Jumo 211**, a liquid-cooled inverted V-12 engine. It was the direct competitor to the famous Daimler-Benz DB 601 and closely paralleled its development. While the Daimler-Benz engine was mostly used in single-engined and twin-engined fighters, the Jumo engine was primarily used in bombers such as Junkers' own Ju 87 and Ju 88, and Heinkel's H-series examples of the Heinkel He 111 medium bomber.

The Jumo 211 became the major bomber engine of the war, in no small part due to Junkers also building a majority of the bombers then in use. Of course, since it was the Luftwaffe that selected the final engine to be used after competitive testing on prototypes (such as the Dornier Do 217), there is certainly more to it.

Limited production capacity for each type, and the fact that the Jumo was perfectly capable (if not superior) in a bomber installation meant that it made sense to use both major types to the fullest; since the Daimler had a slight edge in a lightweight, single-engine application, that left the Jumo to fill in the remaining roles as a bomber engine. Even this wasn't enough in the end, and radial engines like the BMW 801 were increasingly put into service alongside the Jumo and DB series, most often in multi-engine installations like the Jumo. It was the most-produced German aviation engine of the World War II years.



Abb. 16. Junkers-Motor Jumo 211 (Seitenansicht) (Werkphoto)

Operating Limits

- Min coolant temperature: 60 deg C.
- Max coolant temperature: 110 deg @ 1000 m, 100 deg @ 4000 m
- Min oil temperature: 30 deg C.
- Max oil temperature: 105 deg C.

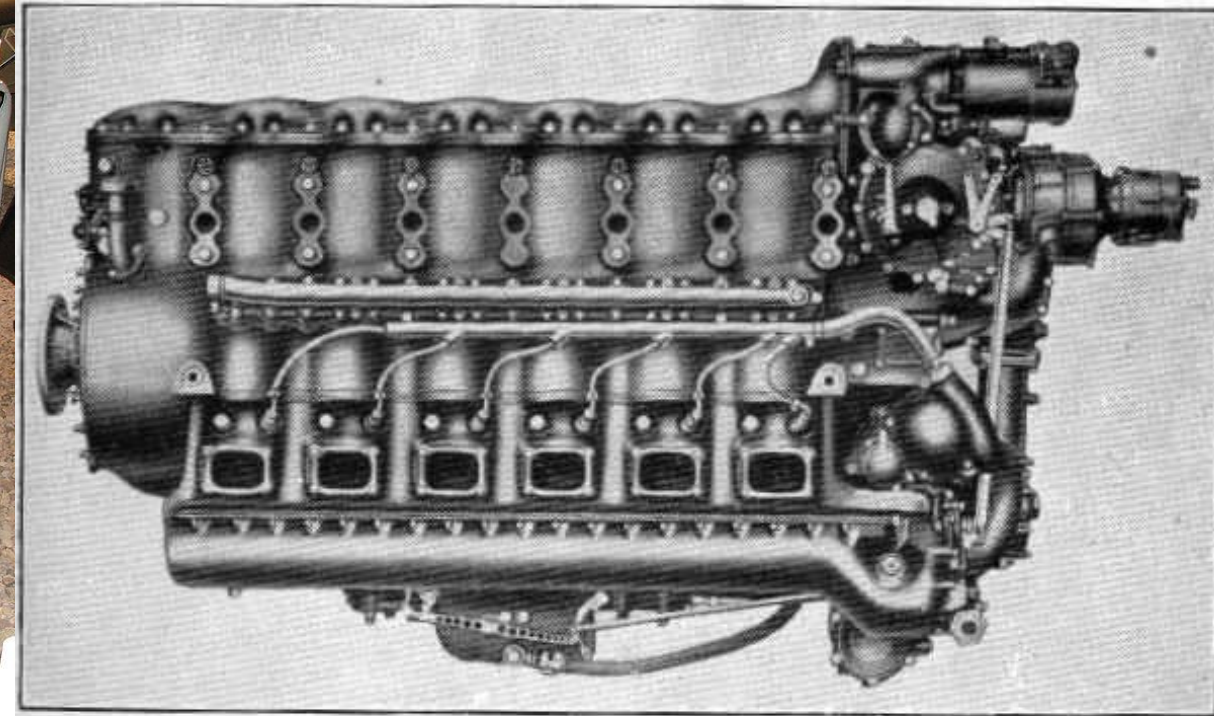
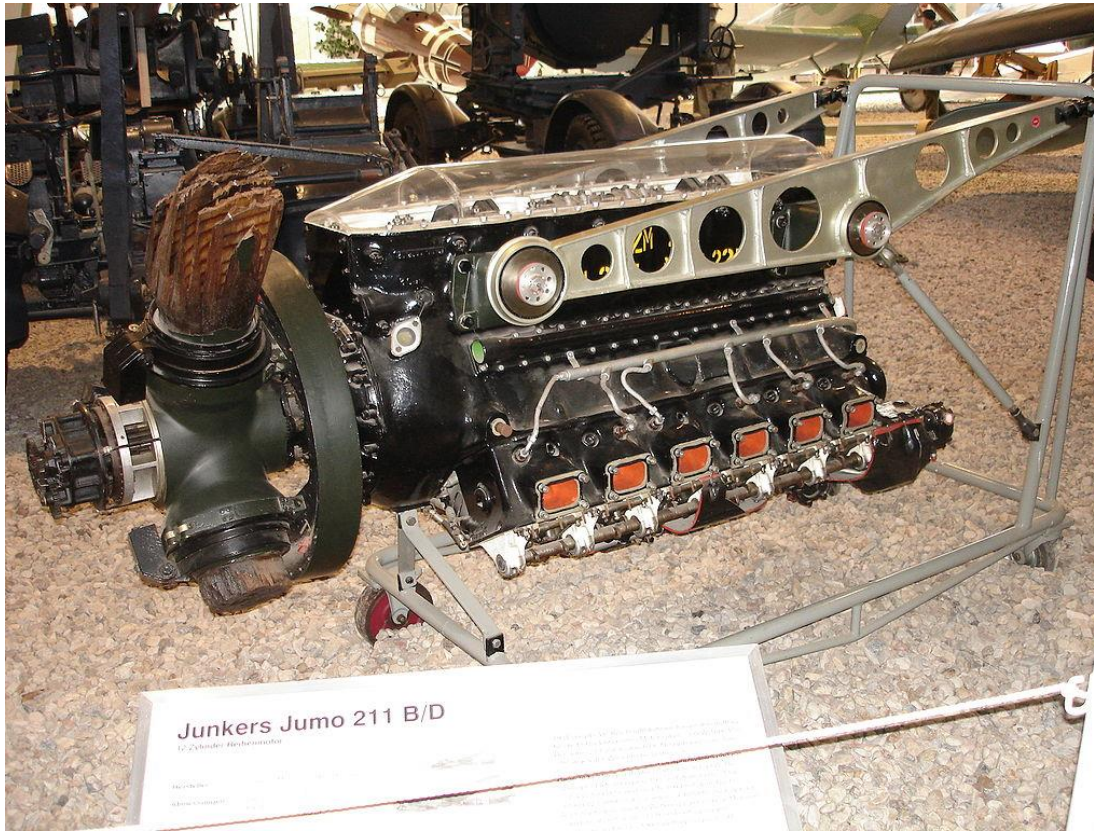
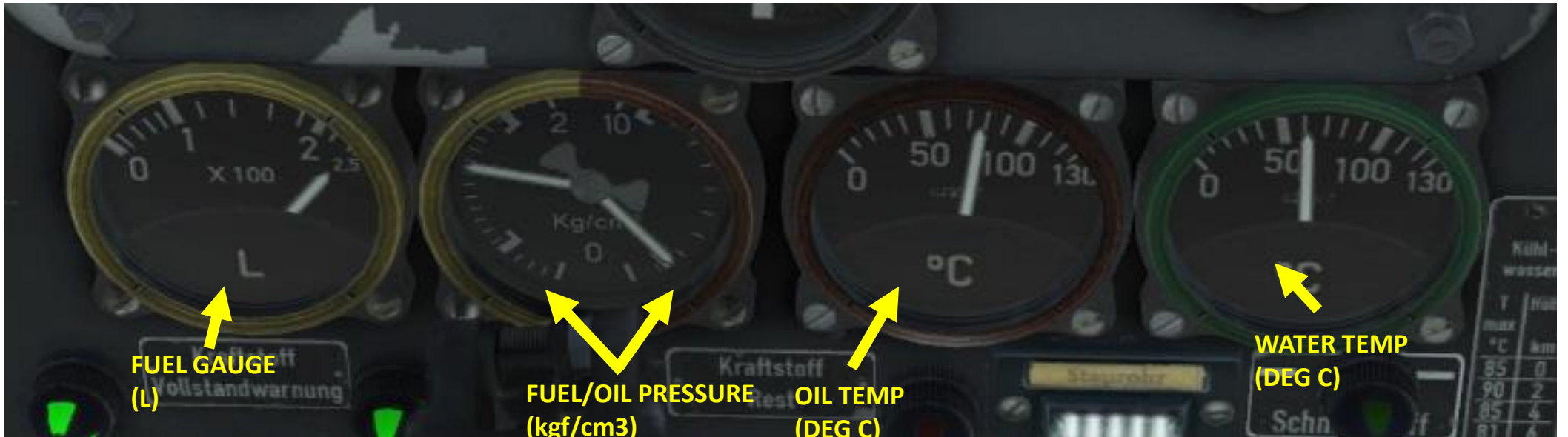

Recommended Settings

- **CAUTION: AVOID RAPID INCREASE OF THROTTLE.**
- **CAUTION: AVOID PROLONGED RPM OVER 2250.**
- Takeoff
 - 2500 RPM, 1.3 ATA
- Climb
 - 2450 RPM, 1.25 ATA, speed 240 kph
(30 min max)
- Normal Operation (Cruise)
 - 2100 RPM, 1.2 ATA
- Max Continuous Power
 - 2250 RPM, 1.15 ATA
- Combat
 - 2250 RPM, 1.2 ATA
 - **2600 RPM, 1.40 ATA (1 minute max... or BOOM!)**
- Landing
 - 2000 RPM, 0.6 ATA
- **Supercharger** (increases Manifold Pressure @ higher altitudes)
 - **Unlike other superchargers models in the game, the Stuka supercharger has an “automatic” mode and a “manual” mode.**
 - Lshift + S to toggle supercharger modes



PART VI: AIRCRAFT PERFORMANCE

- Range: 500 km
 - With 500 kg bomb load
- Fuel Max Capacity: ~780 L
- Endurance: 135 min (2h15)
 - No bomb load
- Operational ceiling: 8500 m
- Optimal Climb Speed: 230 kph
- Best climb Speed: 415 m/min
 - With 4 * 50 kg + 500 kg bomb
- Note: Your fuel and bomb loadout will impact your aircraft's performance, but also your weapon loadout (i.e. 37 mm guns). Performance data often being subject to many factors (test conditions, state of aircraft (captured vs factory fresh), etc.), these numbers are to be taken with a grain of salt. Just like today, aircraft performance can and will vary between the real values and the values that you get on paper.

